

# MONOSEM

*The precision Planter specialist*

# MS



*Pneumatic planter for market gardening crops*

[www.monosem.com](http://www.monosem.com)



EN

## STEMMING FROM MONOSEM EXPERIENCE

*With the MONOSEM experience in precision planters, the MS range has been specially designed for sowing small seeds.*

*Simplicity, reliability, precision, robustness and versatility have, for over nearly 20 years, made the reputation of the MS range. This quality of manufacture, together with the advice from the MONOSEM specialists and the wide choice of equipment will enable you to plant with a planter which meets perfectly with your requirements.*





## SUMMARY

Pages

Planting methods.....	4
The MS seed placement.....	5
The metering system.....	6
MS Metering unit.....	9
MS A Metering unit.....	10
MS C Metering unit.....	11
MS B and B2 Metering units.....	12
MS D and D2 Metering units.....	13
The frame components.....	14
The rigid frames.....	16
The folding frames.....	18
The fertilizers.....	20
The Microsem.....	21
The seed monitors.....	22
Technical features.....	23

	Single line		Double line		Strip
Type of planting					
			50 or 70 mm	80 to 110 mm	67 mm
Inter-row spacing	14 to 20 cm	20 cm and +	20 cm and +	26 cm and +	20 cm and +
Metering unit	MS B or B2 1 line per metering box	MS A MS B or B2 1 line per metering box	MS C 2 lines per metering box	MS D or D2 1 line per metering box	MS A MS C 1 strip per metering box
Page	P. 12	P. 10 or 12	P. 11	P. 13	P. 10 or 11

Planting modes (examples)	Sowing on flat ground		Sowing on ridges	
	In the field	In beds	In the field	In beds
	Planting in the field	Planting on 1 bed per passage	Planting in the field	Planting on 1 bed per passage
		Planting on 3 beds per passage		Planting on 3 beds per passage

# THE MS SEED PLACEMENT

The seed placement principle of the MS metering units is based on the control of the depth by the front gauge wheel and planting with shoes.

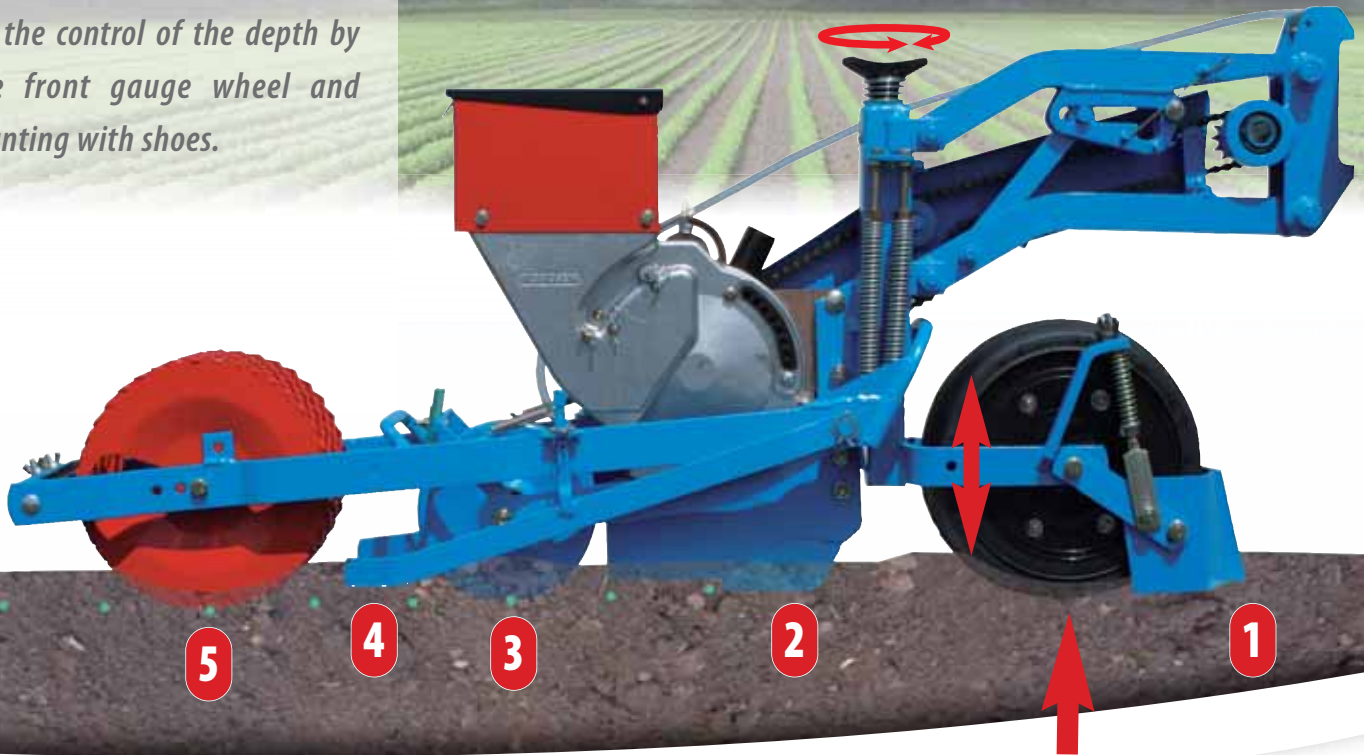

1) The clod remover clears the future planting line of clods or stones whilst the gauge wheel presses the soil and controls the depth.



2) The shoe opens the furrow (or the furrows) at a depth defined by the front gauge wheel.



3) The intermediate press wheel\*, adjustable in pressure, presses down the seeds into the bottom of the furrow for regular and rapid plant emergence.  
\*except MS versions B and D



4) The scrapers\* (retractable if necessary) scrape fine soil over the seeds.  
\*except MS version B



5) The rear wheel closes the furrow around the seed for optimal seed germination.

Quality planting depends first of all on a good metering systems. This is why MONOSEM uses all their know-how so as to propose a precise, simple and very reliable metering system. This quality of manufacture will enable you to plant the smallest seeds with great precision.

1



### Metering box

The metering box made from bronze ensures a perfect seal with the disc without risk of the phenomenon of static electricity.

2



### Discs

The stainless steel discs 1 mm thick are very rigid. The agitator, fixed on to the disc stiffens the unit. The changing of the discs is easily made without tools. A complete range of discs for all precision seeds is available.

3

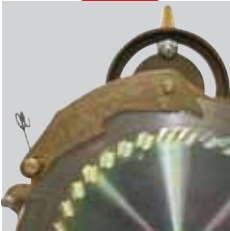

### Scraper

The brass scraper avoids doubles. A spring on the metering box cover maintains the selector perfectly in place against the disc for optimal selection, even with small seeds.

4

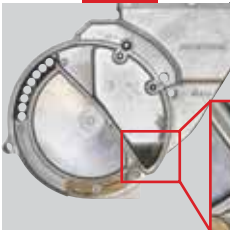

### Cover

The cover in alloy is specially designed for planting with a minimum of seeds. A fiber gasket provides a seal between the disc and cover.

5



### Control window

The distribution system is easily accessible, for both adjustments and control. A large transparent window allows for control of the selection after the selector.

6

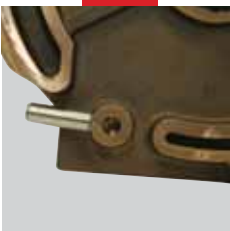

### Air jet cleaning

After the seeds have dropped, a jet of air removes any dust and residue of seeds that could get stuck in the holes of the discs.

4



7

### Selection adjustment

**+** The same adjustment on all the rows due to the quality of MONOSEM manufacture !

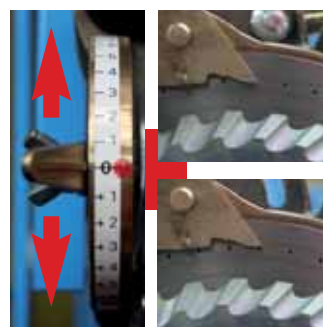

The selection adjustment is made using a single lever which is easily accessible on the top of the metering boxes. The quality and the precision of the MS metering boxes enables an identical adjustment on all of the units.

## MONOSEM quality of manufacture and precision !

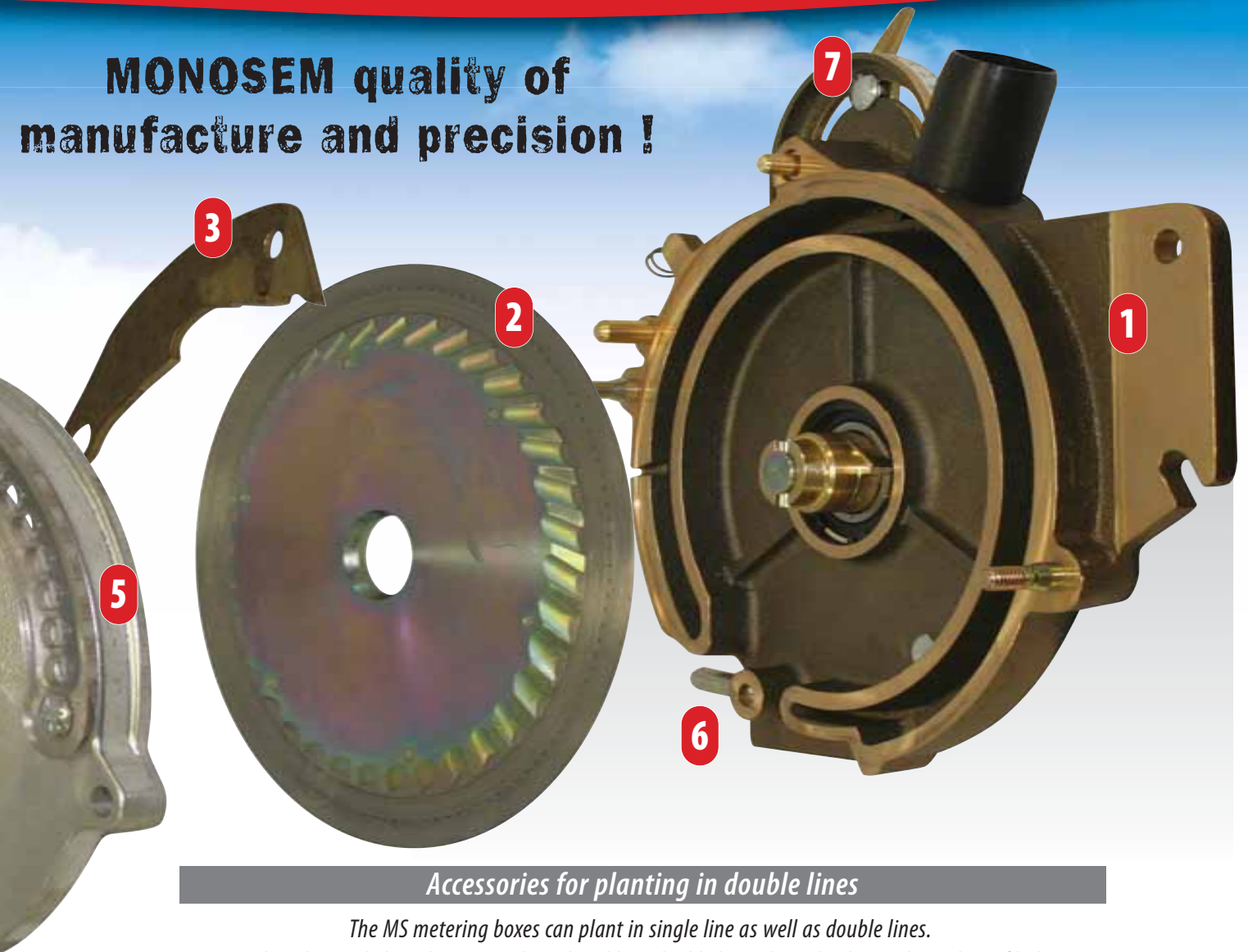

### Accessories for planting in double lines

The MS metering boxes can plant in single line as well as double lines. For this, the single line shoe is simply replaced by a double lines shoe, the disc with one line of holes is replaced by a disc with 2 lines of holes and a 2nd selector is added.

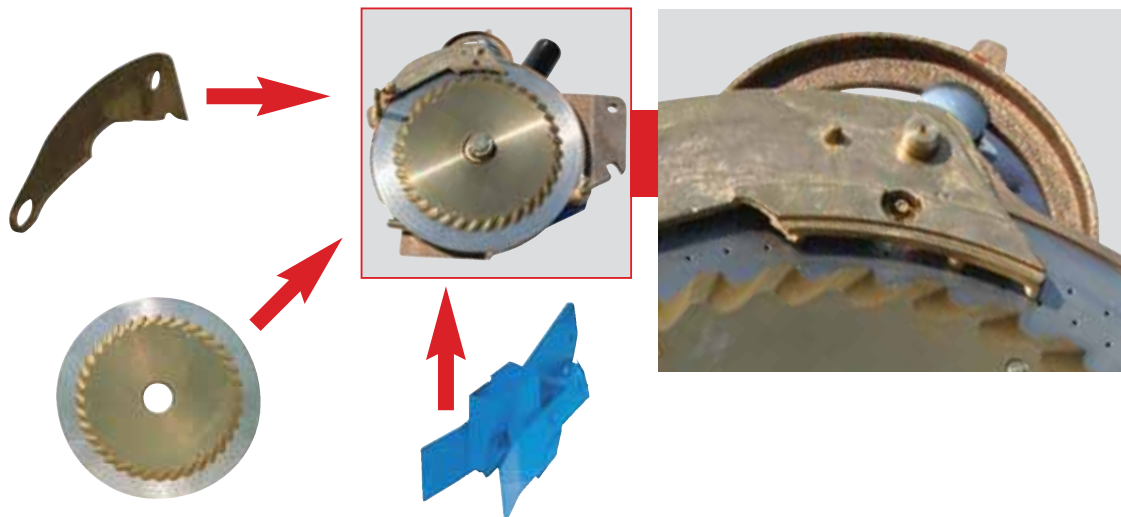

**+ One single adjustment of the 2 selectors**

**+ Single row and double row on the same unit !**

## MAIN MS SEED DISCS



Single row disc



Double row disc

Number of holes		Distance on the row (seed spacing gearbox and standard sprockets)	Diameter of holes (mm)
Single row disc	Double row disc		
18	2 x 18	12,3 to 32,7 cm	0,5 - 0,6 - 0,65 - 0,7 - 0,8 0,9 - 1 - 1,2 - 1,5 - 1,8 2 - 2,5
30	2 x 30	7,4 to 19,6 cm	
36	2 x 36	6,2 to 16,4 cm	
60	2 x 60	3,7 to 9,8 cm	
72	2 x 72	3,1 to 8,2 cm	
120	2 x 120	1,8 to 4,9 cm	0,5 - 0,6 - 0,65 - 0,7 - 0,8 0,9 - 1 - 1,2 - 1,5 - 1,8
180	2 x 180	1,2 to 3,3 cm	

Please consult us for all special seed populations or hole diameters (double lines, hill dropping...)

Diameter of holes (mm)	Types of seeds (just given as a guide)
2,5	
2,2	Chard, pelleted lettuce
2	Asparagus, Sugar beet, Beetroot, pelleted fennel, Pelleted onion, pelleted parsnip
1,8	Cucumber, Spinach, Lentil, Melon, Radish, Black Radish
1,7	Gherkin
1,5	Paprika
1,2	Pelleted carrot, Cabbage, Coriander, Unpelleted onion, Radish, Tomato
1	Broccoli, unpelleted Fennel, Mustard Pepper, Swede
0,9	Shallot, Turnip
0,8	Lambs Lettuce, Poppy
0,7	Basil, unpelleted Carrot, Chives, Parsley
0,65	Chicory, Endive
0,6	
0,5	Celery, unpelleted Lettuce





# MS METERING UNIT

The MS metering unit has been specially designed for market gardening crops. Seed drop precision, regularity of depth, emergence dynamics and the simplicity of adjustment are the main assets of the MS metering unit.



**1 Hopper**

Without hopper extension    Extension 1,5L    3L Hopper

The MS metering units are delivered, in standard version, with a 1,5-litre extension. If required, the units can be supplied without extension or with a 3-litre hopper.

**2 Parallelogram**

The heavy-duty parallel linkage is mounted on interchangeable bushings. For soft ground, a relief spring is on option.

**3 Metering unit head**

The MS metering unit head is equipped as standard with a manual row cut-off.

**4 Front gauge wheel**

On MS metering units, the depth control is made with the front wheel. The wheels mounted on ball bearings, are available in different models according to your requirements and according to the version of metering unit. The depth adjustment is made using a hand wheel (10). A scale enables to check the precision of depth adjustment when planting.

**5 Shoe**

The MS unit shoes can be removed and have an interchangeable tip. Different models of shoes are available according to the type of planting (single line, double lines or strip) and according to the type of soil (rounded tip, short wings, long wings,...).

**6 Intermediate press wheel with adjustable pressure**

The MS units are equipped with intermediate press wheels for pressing the seeds down into the bottom of the furrow and also to improve the seed-to-soil contact (except MS B and D units). The pressure on the ground of this press wheel can be adjusted (11).

**7 Scrapers**

The MS units are equipped with scrapers in the standard version for closing the furrow (except on MS B units). These scrapers can be individually adjusted in height and are retractable.

**8 Rear press wheel unit with adjustable pressure**

Different models of wheels are proposed for closing and firming the furrow. The pressure on the ground of these wheels is adjustable (12).

**9 Relief spring (option)**

For light, supple soils, a double adjustable relief spring helps to relieve the metering unit.

The MS A unit can be converted into a MS C unit by replacing the shoe and the disc and adding a 2nd press wheel and a 2nd selector.



### Inter-row spacings

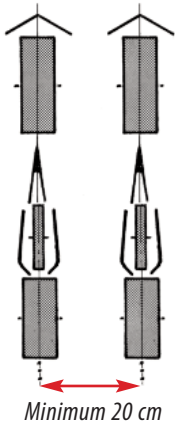

### Planting method

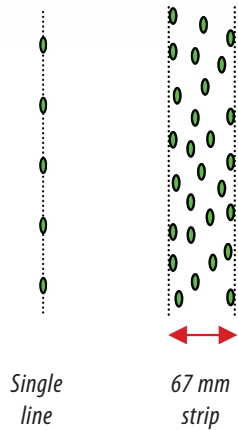

### Standard equipment

- 1** Adjustable clod remover
- 2** Front self-cleaning 300 x 100 wheel
- 3** Narrow pointed shoe with short wings
- 4** Narrow intermediate stainless steel press wheel with plastic scraper and adjustable pressure spring
- 5** Intermediate scrapers individually adjusted and retracted
- 6** Rear cage wheel 250 x 120

Weight (standard metering unit only) : 52 kg

### Additional equipment

Rear wheel



Flat steel 210x100 or 250x105 wheel



250x120 cage wheel with flat profile



Tyre for 250x120 cage wheel (standard cage wheel or with flat profile)



Concave wheel



Self-cleaning tyre for cast iron concave wheel



Flat self-cleaning 250x145 wheel

Shoe and intermediate press wheel



Intermediate press wheel with self-cleaning supple tyre

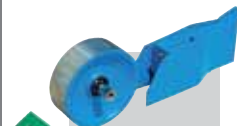

Spreader shoe with wide press wheel for sowing on 67 mm beds



Narrow pointed shoe with long wings



Narrow shoe with rounded tip, short wings



Narrow shoe with rounded tip, longer wings

Front wheel



Flat steel 250x105 wheel



Flat self-cleaning 250x145 wheel

# MS C METERING UNIT

The MS C unit can be converted into a MS A unit by replacing the shoe and the disc and removing the 2nd press wheel and the 2nd selector.



## Inter-row spacings

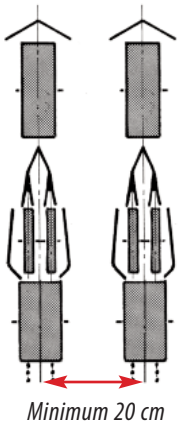

## Planting method

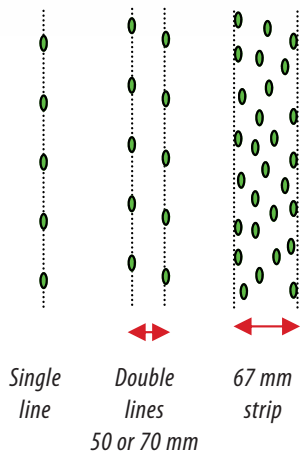

## Standard equipment

- 1** Adjustable clod remover
  - 2** Front self-cleaning 300 x 100 wheel
  - 3** Clod removers for double row shoe
  - 4** Double row shoe 70 mm spacing (50 mm on option)
  - 5** Double narrow intermediate stainless steel press wheels with plastic scrapers and adjustable pressure springs
  - 6** Intermediate scrapers individually adjusted and retracted
  - 7** Rear cage wheel 250 x 120
- Weight (standard metering unit only) : 57 kg

## Additional equipment

Rear wheel



250x120 cage wheel with flat profile



Flat steel 210x100 or 250x105 wheel



Self-cleaning tyre for rear cage wheel 250x120



Flat self-cleaning 250x145 wheel

Shoe and intermediate press wheel



Intermediate press wheel with self-cleaning supplie tyre



Double lines shoe with press wheels for planting on double lines of 50 mm

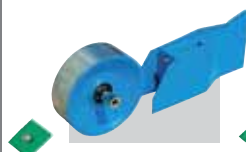

Spreader shoe with wide press wheel for sowing on 67 mm beds

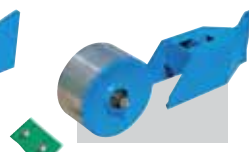

Spreader shoe with wide press wheel for sowing on 100 mm beds (consult us)

Front wheel

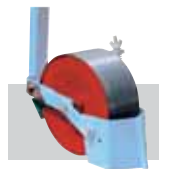

Flat steel 250x105 wheel



Flat self-cleaning 250x145 wheel



MS B metering unit (Without intermediate steel press wheel)

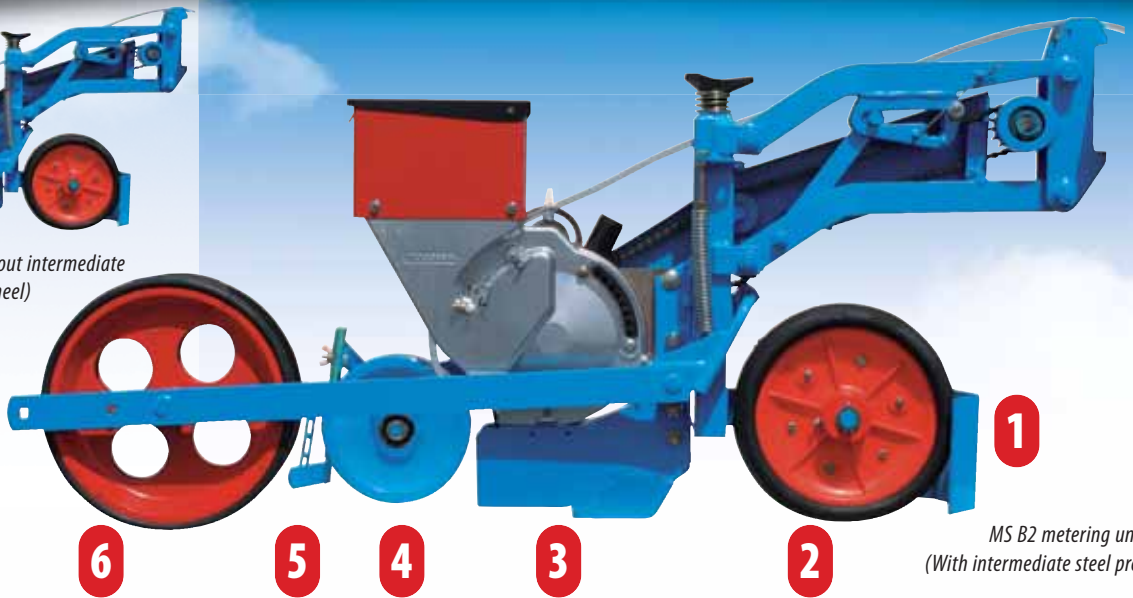

MS B2 metering unit (With intermediate steel press wheel)

### Inter-row spacings

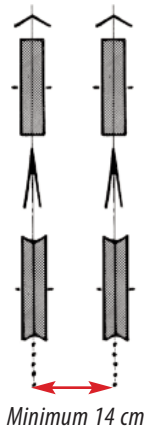

### Planting method



### Standard equipment

- 1** Clod remover
- 2** Front self-cleaning 285 x 65 wheel
- 3** Narrow pointed shoe with short wings
- 4** Narrow intermediate stainless steel press wheel with plastic scraper and adjustable pressure spring (not compatible with the MS B metering unit)
- 5** Intermediate scraper (not compatible with the MS B metering unit)
- 6** Rear cast iron concave wheel with self-cleaning tyre

Weight (standard metering unit only) : 46 kg

### Additional equipment

Rear wheel



Rear concave wheel

Shoe and intermediate press wheel



Shoe with rounded tip and short wings



Narrow pointed shoe with long wings



Shoe with rounded tip and longer wings

Front wheel

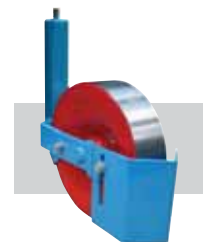

Front stainless steel wheel

# MS D AND D2 METERING UNITS



MS D metering unit  
(Without intermediate steel press wheel)



MS D2 metering unit  
(With intermediate steel press wheel)

## Inter-row spacings

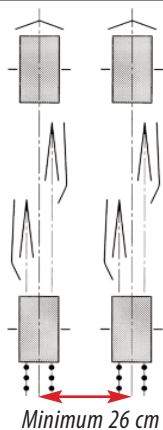

## Planting method

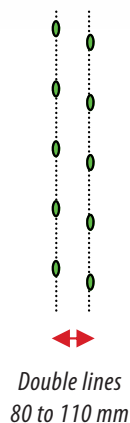

## Standard equipment

- 1 Adjustable clod remover
- 2 Front self-cleaning 250 x 170 wheel
- 3 Narrow pointed shoe with short wings
- 4 Narrow intermediate stainless steel press wheel with plastic scraper and adjustable pressure spring (not compatible with the MS D metering unit)
- 5 Intermediate scrapers individually adjusted and retracted
- 6 Front self-cleaning 250 x 170 wheel

Weight (standard metering unit only) : 79 kg

## Additional equipment

Rear wheel

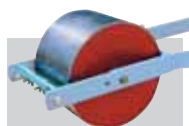

Flat steel 250x170 wheel



Cage wheel 250x170

Shoe and intermediate press wheel



Intermediate press wheel with self-cleaning supple tyre (not compatible with the MS D metering unit)



Narrow pointed shoe with long wings



Shoe with rounded tip and short wings



Shoe with rounded tip and longer wings

Front wheel



Flat steel 250x170 wheel

The MS planters are equipped with TIP 5" frames. This type of frame, together with the unit fixing system and the planter components, offer a vast choice of assembly configurations, row spacings and equipment.

## Assembly of the units with clamps



The assembly of the units with clamps ensures a reliable and solid fixing of the units. If necessary, the units can be moved in order to modify the inter row spacing by loosening the clamps. This method of fixing excludes the risk of the metering unit sliding sideways when working.



## 1 Wheel units with adjustable height

On the MONOSEM planters, all the wheels drive the seed discs. This system ensures a smooth drive and so a better planting regularity. Three types of wheel units are offered. All are equipped with a slip clutch for a smooth drive of the seed discs in irregular ground conditions. The wheel units have a system of height adjustment and are offered with narrow (500 x 15) wheels (except adjustable wheel unit with screw).



Adjustable wheel unit with 500 x 15 wheel  
Minimum inter-row spacings (1) : 36 cm  
Wheel clearance: 25 cm



Adjustable wheel unit with 500 x 15 wheel and integrated metering box  
Minimum inter-row spacings (1) : 43 cm  
Wheel clearance: 25 cm



Adjustable wheel unit with 6,5 x 80 x 15 wheel  
Minimum inter-row spacings (1) : 45 cm  
Wheel clearance: 19 cm

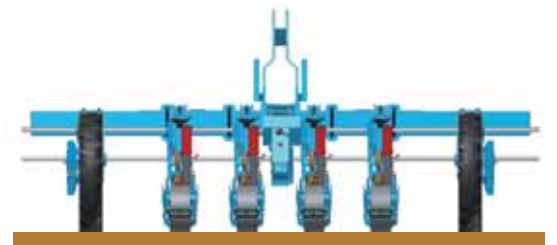
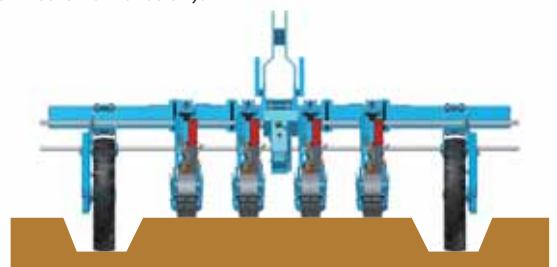

The wheel units that can be adjusted in height enable planting on flat ground or on ridges.



Safety clutch

(1) Minimum inter row spacing for a configuration with wheel unit placed between 2 metering units (according to equipment)



## Platform (option)



A planting inspection platform is available on option on the MS planters. This platform, of 2m70 wide, is equipped with a safety handrail.

## Row markers (option)

The MS planters can be equipped on option with row markers. Different models are available according to the types of folding and width of the planter.



Manual row marker with shoe



Hydraulic row marker with disc (version with shoe also available)



Hydraulic folding row marker with disc for folding frame (different models depending on the frame)

2

## Seed spacing gearbox

According to the required inter row spacing, the MS planters are equipped with a central or rear seed spacing gearbox or a gearbox integrated into the wheel unit. These gearboxes have 16 ratios for precise adjustment of the seed population.



Central seed spacing gearbox  
Minimum inter-row spacings (1) : 33 cm

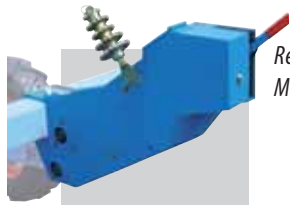

Rear seed spacing gearbox  
Minimum inter-row spacings (1) : 20 cm



Seed spacing gearbox integrated into the wheel unit  
Minimum inter-row spacings (1) : 43 cm

(1) Minimum inter row spacing for a configuration with wheel unit placed between 2 metering units (according to equipment)

3

## Turbofan



The MONOSEM turbofans are silent, reliable, high performing and ensure a regular vacuum for optimal operating of the seed discs. Our standard turbofans have 19 outlets and are driven by PTO at 540 rpm. On option, they can be driven by PTO at 450 rpm and 1000 rpm and also by hydraulic motor. An universal joint is also proposed on option.

4

## Vacuum cleaner



The MS planters are delivered with a vacuum clean-out system which easily and rapidly retrieves all the seeds left in the bottom of the metering boxes. All the seeds are retrieved in a transparent container.

**+ Emptying is very simple, not a seed lost, using the vacuum clean-out system delivered as standard equipment !**

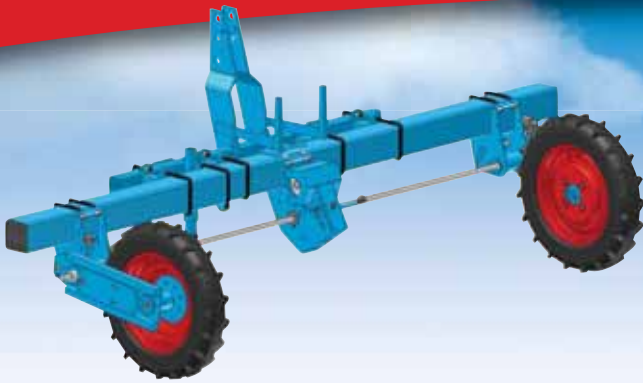

### The rigid Monobar frame

The rigid Monobar frame can be equipped with a bar of 2m up to 3m80. This simple and economic frame can receive up to 12 metering units. The reduced overhang and weight enable it to be hitched up behind relatively light tractors.

MS A Planter - Double bar rigid frame - 3 x 6 rows with Microsem



### The rigid Monoblock frame

The rigid Monoblock frame can be equipped with a bar of 3m up to 4m50. This frame is particularly suitable for a fertilizer attachment.

Frames	Rigid Monobar			
	2 m 00	2 m 20	2 m 60	3 m 00
Length of bar	2 m 00	2 m 20	2 m 60	3 m 00
Maximum number of metering units	5	5	6	9
Minimum inter-row spacings				
Number of « drive » wheel units	2	2	2	2
Number of seed spacing gearboxes	1	1	1	1
Transport width (with transport carriage)	-	-	-	-

Just given as a guide. For other models, please consult us.

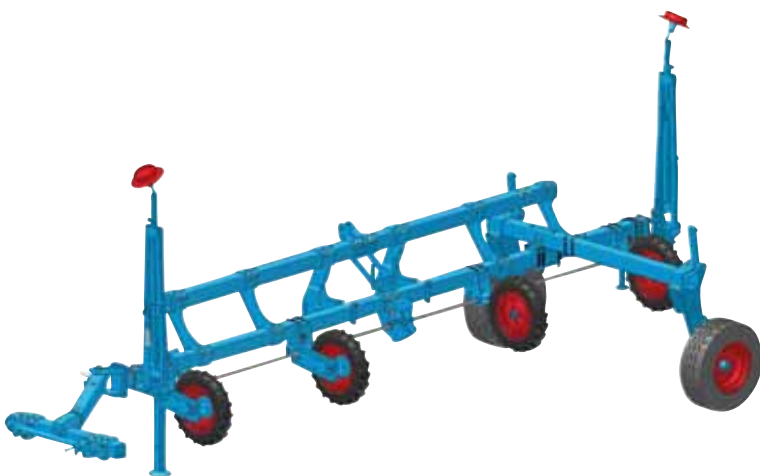

### The rigid Double bar frame

The rigid Double bar frame has a robust and versatile design. The double bar enables a length of bar up to 8m40, i.e. 24 metering units. This frame can also be equipped with fertilizer attachments and also an integrated transport carriage for lengthways transport.



A lengthways transport carriage is available for wide-configuration planters. This transport carriage has a manual or hydraulic wheel lift.



# MONOSEM

The precision Planter specialist



MS C Planter - Monobar rigid frame - 2 rows



MS A Planter - Monoblock rigid frame - 4 rows with fertilizer and Microsem



MS A Planter - Monobar rigid frame - 5 rows with Microsem



MS A Planter - Monobar rigid frame - 3 x 3 rows

		Rigid Monoblock 125		Rigid Double bar		
3 m 50	3 m 80	3 m 00	4 m 50	5 m 70	6 m 60	8 m 40
9	12	9	12	12	18	24
Depending on the metering unit						
2	2	2	2	2	4	4
1	1	1	1	1	1	2
-	-	-	-	2 m 50	2 m 50	2 m 50

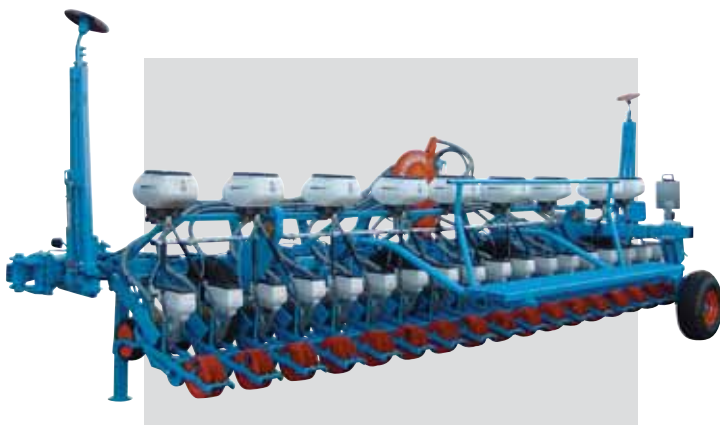

MS A chicory Planter - Double bar rigid frame - 18 rows with Microsem and transport carriage

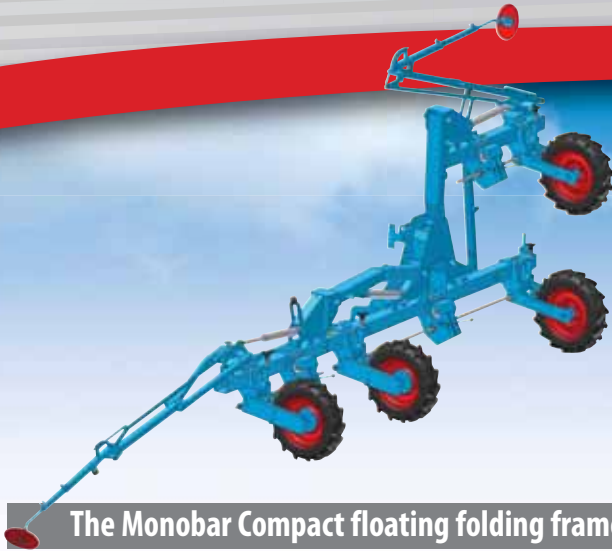

### The Monobar Compact floating folding frame

The floating folding Compact Monobar frame can be equipped with up to 18 metering units. It's folding system makes travelling on the road easier. It's floating wings ensure a perfect following of the ground contours. It's reduced overhang and it's weight mean that it can be hitched up on relatively light tractors.

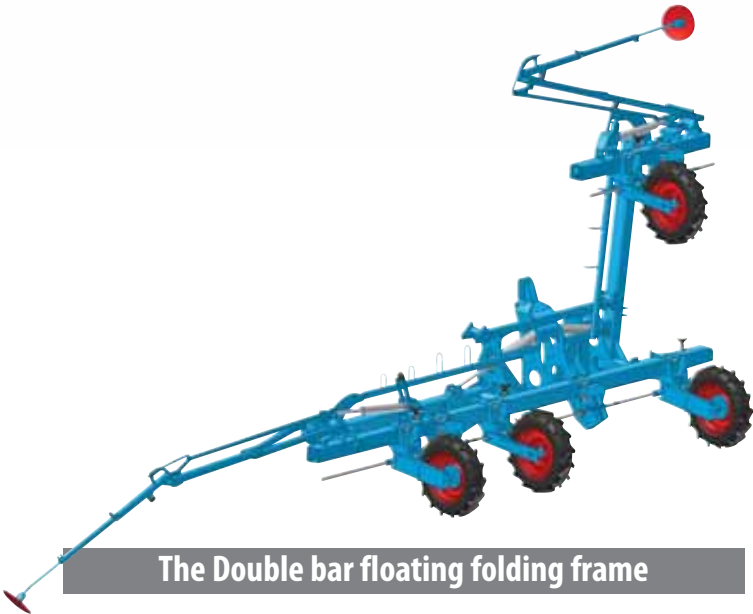

### The Double bar floating folding frame

The floating folding Double bar frame can be equipped with up to 24 metering units. It's folding system makes travelling on the road easier. It's floating wings ensure a perfect following of the ground contours.

MS A Planter - Double bar folding frame - 3 x 8 rows



Frames	Compact fol
Length of bar	5 m 80
Maximum number of metering units	18
Minimum inter-row spacings	
Number of « drive » wheel units	4
Number of seed spacing gearboxes	3
Transport width	3 m 50 (1)

Just given as a guide. For other models, please consult us.  
(1) Depending on inter-row spacings and equipments

## A PERFECT FOLLOWING OF THE GROUND CONTOUR

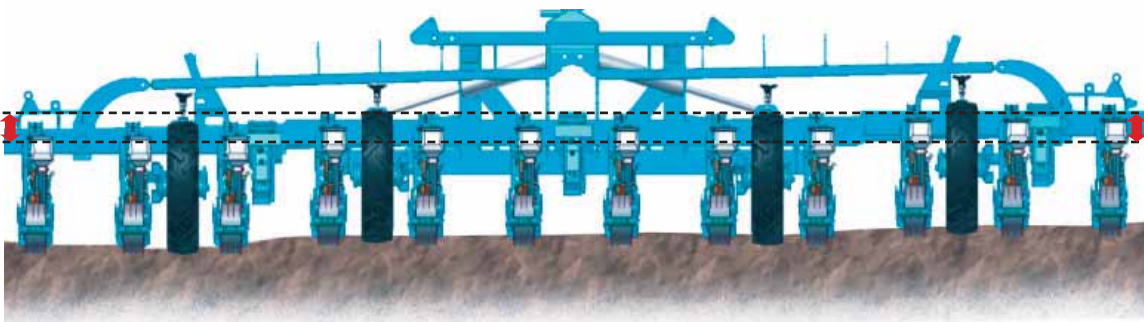

The Compact or Double bar folding frames have independant wings with wheel units. This feature enables a perfect following of the ground contours. In headlands or to finish off a parcel, it is also possible to lift one or other of the wings (or the 2), automatically stopping the seed metering.

# MONOSEM

The precision Planter specialist



MS A Planter - Double bar folding frame - 3 x 8 rows



MS D2 Planter - Double bar folding frame - 3 x 4 double rows with Microsem



MS C Planter - Double bar folding frame - 3 x 4 rows with Microsem

Folding Monobar frame	Double bar folding frame	
6 m 30	6 m 00	7 m 00
18	18	24
Depending on the metering unit		
4	4	4
3	3	3
3 m 50 (1)	3 m 50 (1)	3 m 70 (1)

URS !

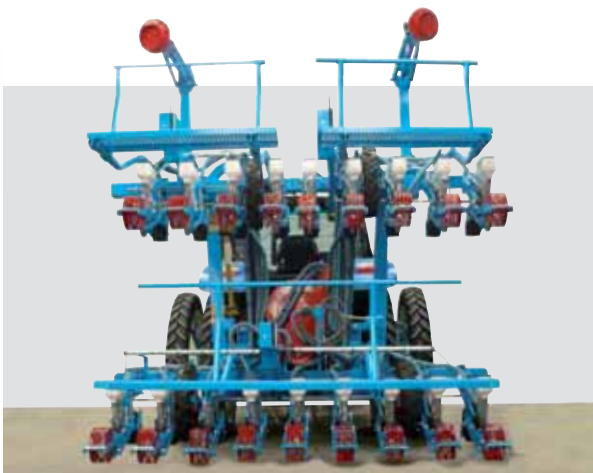

MS A chicory Planter - Double bar folding frame - 18 rows



MS C Planter - Compact folding frame - 3 x 4 double rows

For localized fertilizing during planting, MONOSEM offers hoppers of different capacities and a number of outlets suited to your planter.

## Hoppers

On the MS planters, MONOSEM offers plastic hoppers available in three capacities:

- 85-litre hopper with 1 outlet
- 175-litre hopper with 2 or 3 outlets
- 270-litre hopper with 3 outlets

The fertilizers can be assembled on the rigid Monoblock or Double bar frames.



## Adjustment of the fertilizer

The adjustment of the quantity of fertilizer during planting is made using a gearbox with 12 ratios. The chart delivered with the fertilizers enables a rapid adjustment of the dose.



## Fertilizer tines

The fertilizer product is spread by tines with knives. These tines have a spring safety system and can be adjusted in height.

## Metering by auger

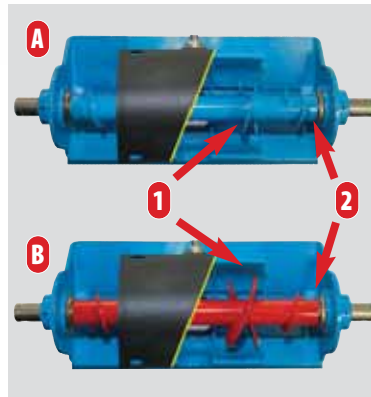

The metering by auger (1), associated with agitators (2), ensure a regular dosing of the fertilizer. These augers in stainless steel are proposed with different pitches to meter exactly the required quantity.

The "Standard" augers (A) are in blue and meter 75 to 325 kg/ha of fertilizer for an inter row spacing of 40 cm.

The "High output" augers (B) are in red and meter 150 to 650 kg/ha of fertilizer for an inter row spacing of 40 cm.



	Inter row spacing under 40 cm	Inter row spacing over 40 cm
Capacity	Capacity according to the number of rows and the inter row spacing	
Configuration	2 outlets per row	1 outlet per row
Output	75 to 325 kg/ha at 40 cm inter row spacing with standard auger	150 to 650 kg/ha at 40 cm inter row spacing with standard auger
Type of frame	Rigid Monoblock Rigid Double bar	

Configurations and outputs given as a guide. Please consult us.

# THE MICROSEM



The precision Planter specialist

Whether for insecticide or helicide, the Microsem system with auger ensures a regular metering of microgranules. Its simple design enables an easy and reliable use. Multi-purpose, the Microsem is compatible with the majority of microgranulate products on the market (insecticides, helicides,...).



## Insecticide Microsem

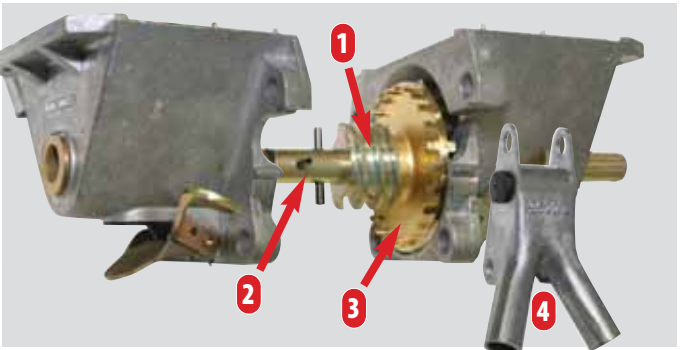

The principle of the Microsem metering resides in the auger system. The microgranules contained in the hopper are taken up by 2 augers (1). The agitators (2) enable a regular feed of these augers. A finger wheel (3) then spread the product uniformly in the chutes (4).

## Adjustment of the Microsem



The adjustment of the microgranulators is made using a 3-level gearbox. It offers a wide range of adjustments (40 ratios) to meet with the majority of requirements.

## Chutes

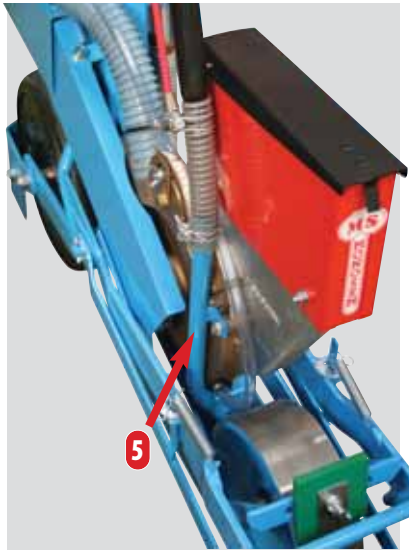

The insecticide Microsem tube (5) is placed just behind the shoe so as to distribute the product in the planting line.

## Emptying of the hoppers

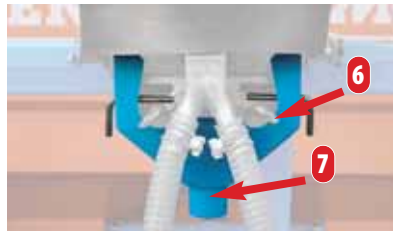

The capacity of the Microsem hoppers is 20L. The trapdoors (6) and the chute (7) enable simple and easy emptying of the remaining product.

# HECTARE COUNTERS AND SEED MONITORS

Specialist in precision planters, MONOSEM offers a wide range of seed monitors. From the simple checking of the seed drop to the counting with indication of the distance between seeds, you will find the monitor suited to your requirements.



Functions	Electronic hectare counters	Seed monitors		
		CS 1000	CS 3000	CS 7000
Seed drop control row by row	-	●	●	●
Alarm if no seed	-	●	●	●
Stop alarm	-	●	●	●
Alarm programmable threshold	-	-	●	●
Working speed by sensor	●	-	●	-
Working speed by radar	-	-	○	●
Total surface	●	-	●	●
Partial surface	●	-	●	●
Average population	-	-	●	●
Distance between seeds	-	-	●	●
Maximum number of rows	A, B or B2 metering units	16	32	32
	D or D2 metering units	8	16	16
Seed population control	-	-	-	●
ISOBUS compatible (ISO 11783)	-	-	-	●

● : Standard    ○ : On option    - : Not possible

Seed monitors and Seed-Drive are not compatible with the MS C metering units (double shoes and broadcasting shoes).



The monitor sensors are placed under the metering boxes, inside the shoes. A light beam checks the seed passage, even the smallest of seeds.

## CS 7000 and Seed-Drive



The Seed-Drive hydraulic control of the seed population replaces the planter seed spacing gearbox(es) by several hydraulic motors which drive the seed discs. This system offers the possibility of non-stop modulating of the seed population directly from the tractor cab.

The CS 7000 terminal is the interface enabling the operator to monitor the planter. It is linked to the main control unit (ECU) situated on the planter by a cable with a standardized 9-pin connector. The CS 7000 terminal and the hydraulic control system of the Seed-Drive population are compatible with the ISO 11783 standard called ISOBUS.

## SEED Drive

- Seed sensor
- Hydraulic motor
- 9-pin ISOBUS connector
- ECU Electronic Control Unit

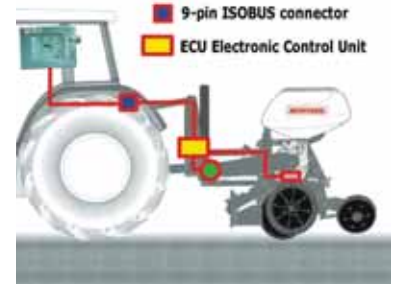

# TECHNICAL FEATURES

## MS MODELS

Frames	Rigid frames											Folding frames				
	Monobar						Monoblock 125		Double bar			Compact		Double bar		
Width	2 m 00	2 m 20	2 m 60	3 m 00	3 m 50	3 m 80	3 m 00	4 m 50	5 m 70	6 m 60	8 m 40	6 m 00	6 m 30	6 m 00	7 m 00	
Transport width <i>(with lengthwise transport carriage)</i>	2 m 00	2 m 20	2 m 60	3 m 00	3 m 50	3 m 80	3 m 00	4 m 50	5 m 70 (2 m 50)	6 m 60 (2 m 50)	8 m 40 (2 m 50)	3 m 50	4 m 10	3 m 50	3 m 70	
Maximum number of rows <sup>(1)</sup>	MS A Metering Unit	6	7	8	9	9	12	9	12	18	18	24	18	18	18	24
	MS B or B2 Metering Unit	8	10	12	12	16	16	16	(2)	24	30	(2)	(2)	(2)	24	(2)
	MS C Metering Unit	6	7	8	9	9	12	9	12	18	18	24	18	18	18	24
	MS D or D2 Metering Unit	4	5	6	6	8	8	6	(2)	12	12	(2)	-	-	12	(2)
Turbofan	Drive by PTO – 540 rpm in standard version, 450 or 1000 rpm on option Hydraulic drive on option. Universal joint on option															
Tyres	2 x (500 x 15)						2 x (500 x 15)		4 x (500 x 15)			4 x (500 x 15)		4 x (500 x 15)		
Seed spacing gearbox (16 settings)	1	1	1	1	1	1 (or 2)	1	1	1	1 (or 2)	2	3	3	3	3	
Hydraulic row markers	○	○	○	○	○	○	○	○	○	○	○	●	●	●	●	
Fertilizer	-	-	-	-	-	-	○	○	○	○	○	-	-	-	-	
Microsem	○	○	○	○	○	○	○	○	○	○	○	○	○	○	○	
Hectare counter	○	○	○	○	○	○	○	○	○	○	○	○	○	○	○	
Seed monitors	○	○	○	○	○	○	○	○	○	○	○	○	○	○	○	
Lighting kit	○	○	○	○	○	○	○	○	○	○	○	○	○	○	○	
Weight frame only	290 kg	295 kg	320 kg	325 kg	365 kg	410 kg	550 kg	580 kg	700 kg	750 kg	1305 kg	1150 kg	1300 kg	1220 kg	1260 kg	

- : Standard
- : On option
- : Not possible
- (1) : Just given as a guide
- (2) : Consult us

For other models and other crops, please consult us.



## Re-sale value

The re-sale value gives a good indication of the quality of a product and its suitability to the market. So when you decide to sell your MONOSEM planter, you will appreciate its high re-sale value.

## MONOSEM quality

The quality has always been a main concern of MONOSEM. This is why when manufacturing the greatest care is taken in the quality control of the products.

## Advice

The MONOSEM partners are specialists who can inform you individually with regards to precision planting and help you choose the planter that meets with your requirements.

## The experience

Across the world, quality and reliability, are very often associated with MONOSEM. A know-how and experience of over 60 years serving agriculture.

## Spare parts

Our spare parts department have available a large stock of original spares and accessories. So even after several years you will be sure to find the parts you require at your MONOSEM partners.



Multi-purpose pneumatic NG Plus 4 planter with discs



Special pneumatic « low-till » planter NX 2 with discs



Multi-purpose pneumatic NC planter with shoes



Special MS vegetable planter for mini-seeds



Mechanical MECA V4 planter for pelleted sugarbeet



Cultivator



The precision Planter specialist

### COMPAGNIE COMMERCIALE RIBOULEAU

8, rue de Berri - 75008 PARIS France

### Factories – Technique - Research - Information

12, rue Edmond Riboulet - 79240 LARGEASSE France

TEL. 00 33 5 49 81 50 00 – FAX 00 33 5 49 72 09 70

Distributor



All the data concerning the equipment, the general appearance, the weight and dimensions are current at the date of printing and vary according to countries.

They may be modified without previous notice. This brochure cannot be considered as a binding document. Your Monosem partner will not hesitate in informing you of any possible changes.

In order to illustrate this brochure, certain safety housings and mechanisms may have been removed. Apart from this particular case and complying with the recommendations in the manual, these must remain fitted.

Ref.: 90300EN - 02/13